

2 4G LED RGBW Controller



Main Characteristics

V8 RF RGBW Remote Control

- Remote Option: RGBW, 4 zones control
- Working Voltage: 3Vdc (Battery CR2032)
- Wireless Frequency: 2.4GHz
- Working Temperature: -30 ~55
- Package Size: L150xW46xH18(mm)
- Weight(G.W.): 85g

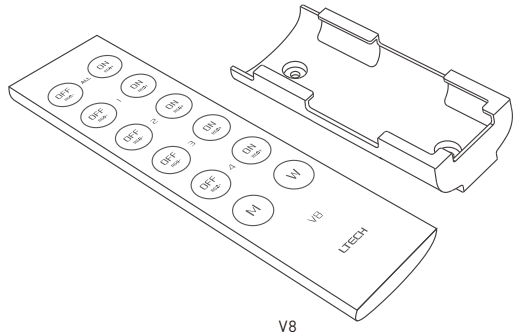

V8

R4-5A CV Receiver

- Input Voltage: 5-24Vdc
- Max Current Load: 5A x 4CH Max. 20A
- Max Output Power: 100W/240W/480W(5V/12V/24V)
- Working Temperature: -30 ~55
- Package Size: L178xW48xH33(mm)
- Weight(G.W.): 150g

R4-CC CC Receiver

- Input Voltage: 12-48Vdc
- Output Voltage: 3-46Vdc
- Output Current: CC 350/700/1050mAx4CH
- Output Power: 1.05W-48.3Wx4CH Max 193.2W
- Working Temperature: -30 ~55
- Package Size: L178xW48xH33(mm)
- Weight(G.W.): 165g

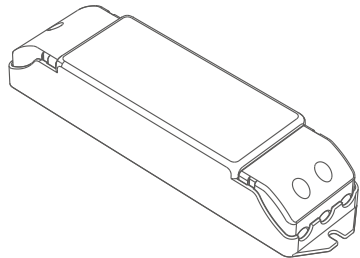

R4-5A/R4-CC

Note: Receiver is sold separately.

Dimensions

Unit: mm

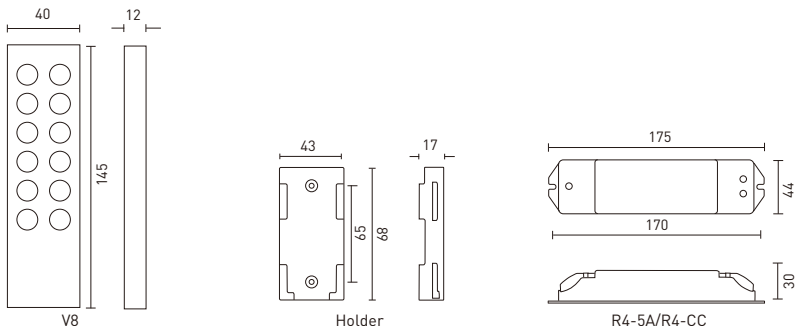

\* V8 remote could be paired with LTECH touch panels, please contact the sales for the operation details.

## Operating Instruction for Remote:

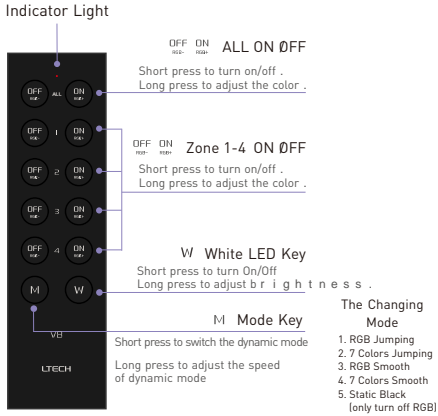

Match/Clear code between remotes

Match code:

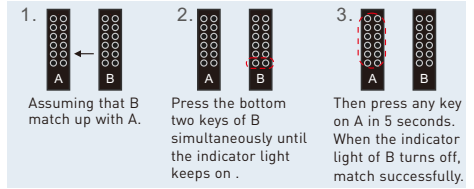

Clear code:

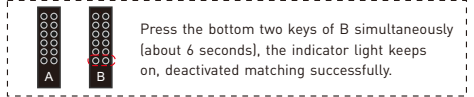

Match/Clear code between remote and receiver

Match code:

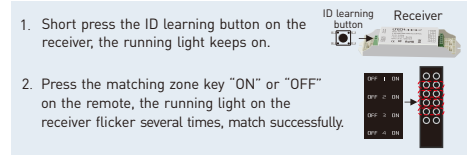

Clear code:

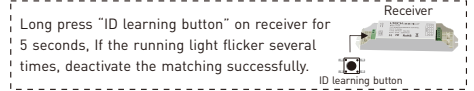

## Operating Instruction for Receiver:

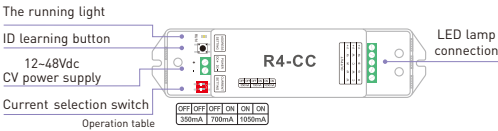

## Wiring Diagram :

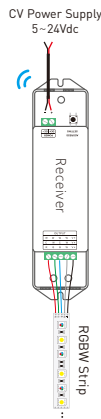
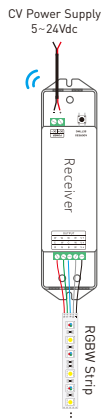

## Attention:

- Please replace the battery if the remote becomes insensitive or control distance is shortened.
- Please take out the battery for long time unused.

◆ Could connect RGB/RGBW LEDs.