

LED Intelligent Driver

- Dimming interface: DALI, Push Dim.
- Dimming range from 0-100%, LED start at 0.1% possible.
- 0-100% flicker-free, achieve the level of high frequency exemption assessment.
- DALI dimming curve: Linear curve or logarithmic curve.
- Over-heat / Over voltage / Over load / Short circuit protection, recover automatically.
- DALI bus standard: IEC62386-101,102, 207.
- Compliant with Safety Extra Low Voltage standard.
- Suitable for indoor I/II/III type lamps application.

Dimmable:

 0.1%-100%

Flicker-free

Achieve high frequency exemption assessment level.



SELV



RoHS



Specification

Model	DALI-75-12-F1M1		DALI-75-24-F1M1	
OUTPUT	Output Voltage	12Vdc	24Vdc	
	Output Voltage Range:	12Vdc ± 0.5Vdc	24Vdc ± 0.5Vdc	
	Output Current	Max. 6.25A	Max. 3.12A	
	Output Power	Max. 75W		
	Output Power Range	0-75W		
	Strobe Level	High frequency exemption assessment level.		
	Dimming Range:	0-100%, dimming depth: Max. 0.1%		
	Overload Power Limitation	≥102%		
	Ripple & Noise	≤200mV		
PWM Dimming Frequency	≤3600Hz			
INPUT	Dimming Interface	DALI (IEC62386), Push Dim		
	Input Voltage	100-240Vac		
	Frequency	50/60Hz		
	Input Current	115Vac≤0.9A, 230Vac≤0.45A		
	Power Factor	PF>0.99/115Vac, PF>0.95/230Vac, at full load		
	THD	<9% at 115Vac, <12% at 230Vac, at full load		
	Efficiency(typ.)	85%	87%	
	Inrush Current(typ.)	Cold start 60A at 230Vac		
	Anti Surge	L-N: 1kV L/N-G: 2kV		
Leakage Current	I/P-O/P: <0.5mA/230Vac, I/P-GND: <0.75mA/230Vac			
ENVIRONMENT	Working Temperature	ta: -30°C ~ 60°C tc: 85°C	ta: -30°C ~ 60°C tc: 80°C	
	Working Humidity	20 ~ 95%RH, non-condensing		
	Storage Temp., Humidity	-40°C ~ 80°C, 10-95%RH		
	Temp. Coefficient	±0.03%/°C (0-50°C)		
	Vibration	10-500Hz, 2G 12min./1cycle, period for 72min. each along X, Y, Z axes.		
PROTECTION	Over-heat Protection	Intelligently adjusting or turning off the output current if the PCB temperature ≥110°C. And the output current will be restored automatically when the temperature comes normal.		
	Over Load Protection	Power limit when rated power ≥ 102%, auto recovers.		
	Short Circuit Protection	Shut down automatically if short circuit occurs, auto recovers.		
	Over Voltage Protection	Shut down the output when non-load voltage ≥15V, re-power on to recover after fault condition is removed.	Shut down the output when non-load voltage ≥27V, re-power on to recover after fault condition is removed.	
SAFETY & EMC	Withstand Voltage	I/P-O/P: 3750Vac I/P-GND: 1800Vac		
	Isolation Resistance	I/P-O/P: 100MΩ/500VDC/25°C/70%RH		
	Safety Standards	IEC/EN61347-1, IEC/EN61347-2-13		
	Strobe Test Standard	IEEE 1789		
OTHERS	Dimension	204×62×34mm[L×W×H]		
	Packing	206×64×39mm[L×W×H]		
	Weight[G.W.]	490g±10g		

* The driver is suitable for connecting resistor current-limiting LED fixture (e.g. LED strip). The instantaneous surge current will be several times increased if connecting built-in constant current IC current-limiting LED fixtures, the driver will activate the overloaded protection (hiccup flickering). When you order, please remark controlling the constant current LED fixture (e.g. MR16 lamp, underground light, LED wall washer, constant current LED strip, etc.), then we can prepare the special programs.

Dimensions

Unit: mm

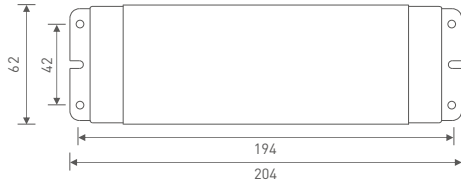

Wiring Diagram

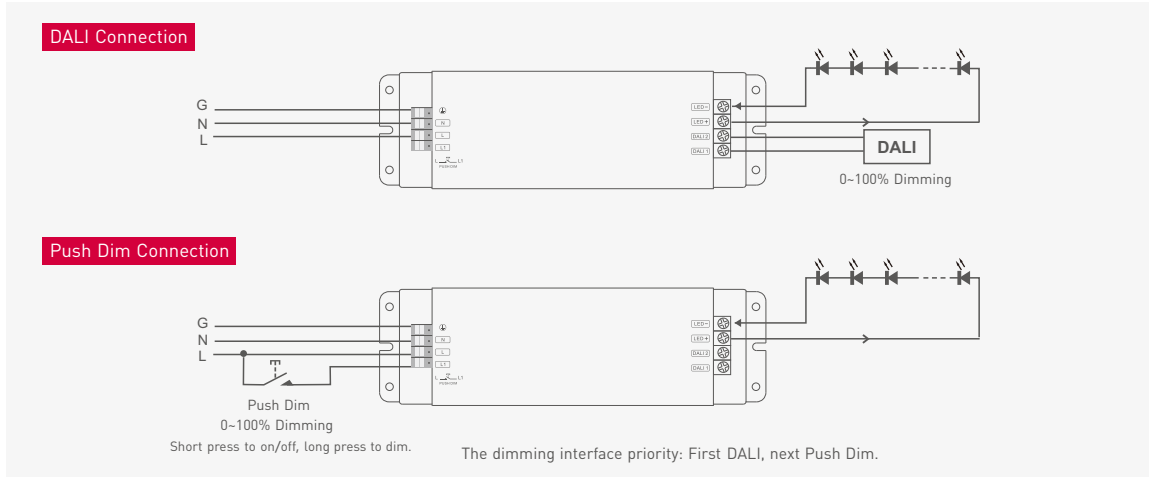

Push Dimming



Reset Switch

- On/off control: Short press.
- Stepless dimming: Long press.
- With every other long press, the light level goes to the opposite direction.
- Dimming memory: Brightness will be the same as previously adjusted when turning off and on again.

* No further notice if any changes in the manual.
Product function depends on the goods.
Please feel free to contact our official distributor if any question.