

Intelligent Full Color RGBW LED Driver (Constant Voltage)

- Small size and light weight. The housing is made from V0 flame retardant PC materials that SAMSUNG/COVESTRO uses.
- The clamshell design and screwless type for strain-relief. The design of dismountable end cap allows you to adjust the length of housing depending on your needs.
- Bluetooth 5.0 SIG Mesh with high networking capability is reliable and stable.
- Gain control on iOS or Android devices through Bluetooth connection.
- With soft-on and fade-in dimming function, enhancing your visual comfort.
- Dimming from 0~100%, down to 0.1%.
- Comply with the EU's ErP Directive, standby power consumption<0.5W.
- The secure and reliable design for signal isolation.
- Innovative thermal management technology intelligently protects the life of the LED driver.
- Overheat, over voltage , overload, short circuit protection and automatic recovery.
- Up to 50,000-hour life time.
- 5-year warranty (Rubycon capacitor).

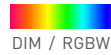

Flicker-Free
IEEE 1789

Dimmable:
.....
0.1%-100%



The certification icon represents on-going certification applications only, and final certification qualification is subject to actual products.

Technical Specs

Model	LM-150-24-G4B1			
Features	Output Type	Constant Voltage		
	Dimming Interface	Bluetooth 5.0 SIG Mesh		
	Output Feature	Isolation		
	Protection Grade	IP20		
	Insulation Grade	Class II (Suitable for class I /II/III light fixtures)		
OUTPUT	Output Voltage	24Vdc		
	Output Voltage Range	24Vdc ± 0.5Vdc		
	Output Current	Max. 6.25A (1.56Ax4CH)		
	Output Power	Max. 150W		
	Output Power Range	0~150W		
	Strobe Level	High frequency exemption level		
	Dimming Range	0~100%, down to 0.1%		
	Overload Power Limitation	≥102%		
INPUT	Ripple	Switch ripple≤150mV, noise≤300mV		
	PWM Frequency	3600Hz		
	DC Voltage Range	200-280Vdc		
	AC Voltage Range	198-264Vac		
	Rated Voltage	220-240Vac		
	Frequency	50/60Hz		
	Input Current	≤0.75A/230Vac		
	Power Factor	PF>0.98/230Vac (at full load)		
	THD	THD<6%@230Vac (at full load)		
	Efficiency (typ.)	93%		
	Standby power consumption	<0.5W		
ENVIRONMENT	Inrush Current	Cold start 45A@230Vac (Test twidth=840us tested under 50% Ipeak)		
	Anti Surge	L-N: 2KV		
	Leakage Current	Max. 0.5mA		
	Working Temperature	ta: -20 ~ 50°C tc: 85°C		
	Working Humidity	20 ~ 95%RH, non-condensing		
PROTECTION	Storage Temperature/Humidity	-40 ~ 80°C, 10~95%RH		
	Temperature Coefficient	±0.03%/°C [0-50°C]		
	Vibration	10~500Hz, 2G 12min/1cycle, 72 min for X, Y and Z axes respectively		
	Overheat Protection	Intelligently adjust or turn off the output current if the PCB temperature ≥110°C, and recover automatically		
	Overload Protection	Shut down the output when current load>102%, and recover automatically		
SAFETY & EMC	Short Circuit Protection	Enter hiccup mode if short circuit occurs, and recover automatically		
	Overvoltage Protection	Shut down the output when non-load voltage>28V, and recover automatically		
	Withstand Voltage	I/P-O/P: 3750Vac		
	Isolation Resistance	I/P-O/P: 100MΩ/500VDC/25°C/70%RH		
	Safety Standards	CCC	China	GB19510.1, GB19510.14
		CE	European Union	EN61347-1, EN61347-2-13, EN62384, EN61547
EMC Emission	CCC	China	GB/T17743, GB17625.1	
	CE	European Union	EN55015, EN61000-3-2, EN61000-3-3, EN61547	
OTHERS	EMC Immunity	EN61000-4-2,3,4,5,6,8,11, EN61547		
	Strobe Test Standard	IEEE 1789		
OTHERS	Gross weight[G.W]	430g±10g		
	Dimensions	352×43×30mm(L×W×H)		

The driver is suitable for connecting resistor current-limiting LED fixture (e.g. LED strip). The inrush current will be dozens of times increased if connecting built-in constant current IC current-limiting LED fixtures, the driver will activate the overloaded protection (hiccup flickering). When you order, please remark controlling the constant current LED fixture (e.g. MR16 lamp, underground light, LED wall washer, constant current LED strip, etc.), so that we can prepare them with special procedures.

Product Size

Unit: mm

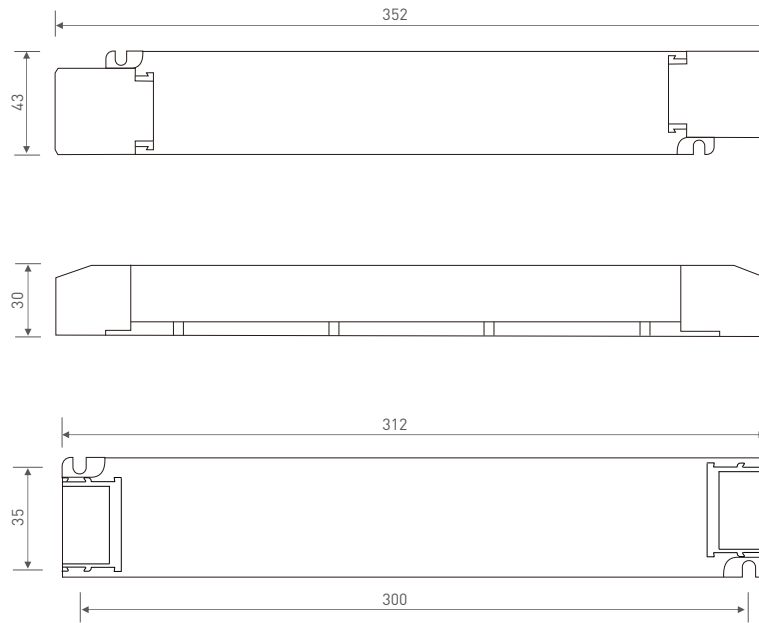

Wiring Diagram

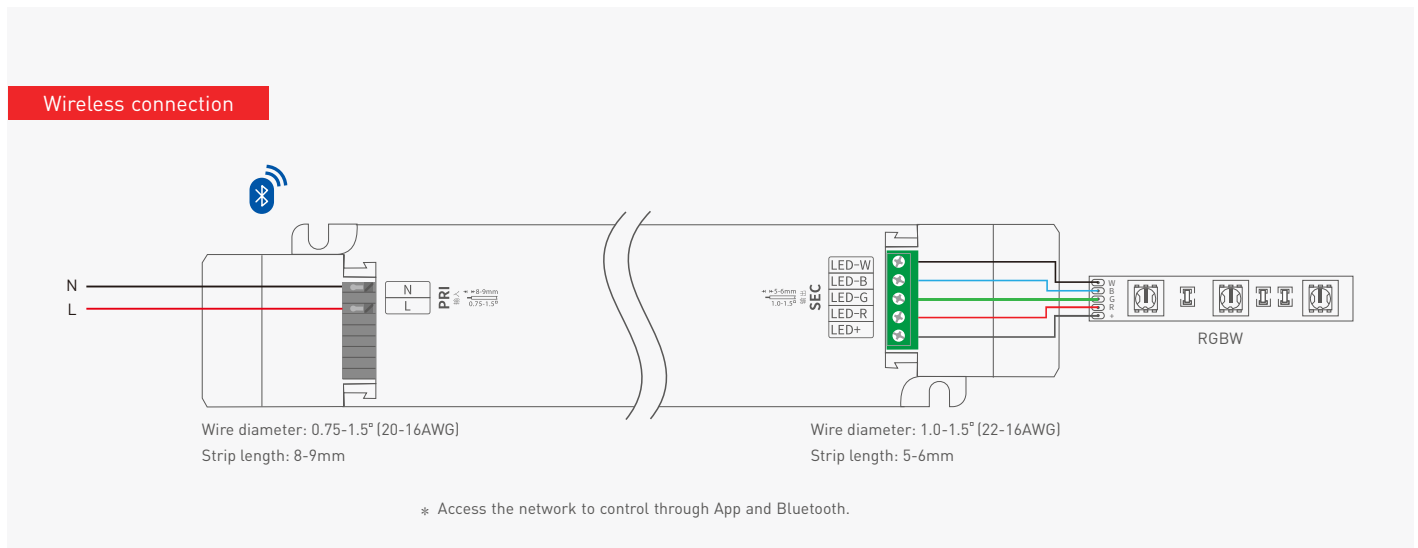

Protective Housing Application Diagram

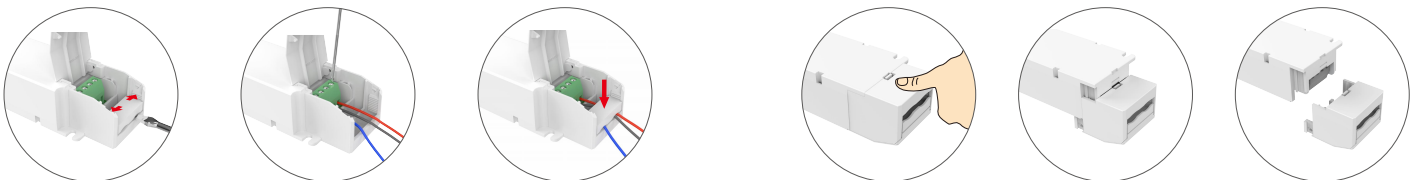

Open the protective housing and push the side housing outwards to pry up the wire fixing board with a screwdriver. Then connect to electrical wires as wiring diagram shows. Press down the wire fixing board to fix the electrical wires, finally close the protective housing.

Press down the back side of the protective housing and move it from side to side to remove it.

Relationship Diagrams

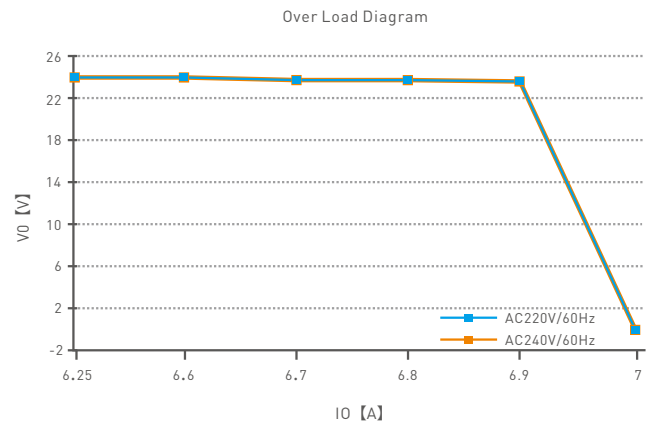
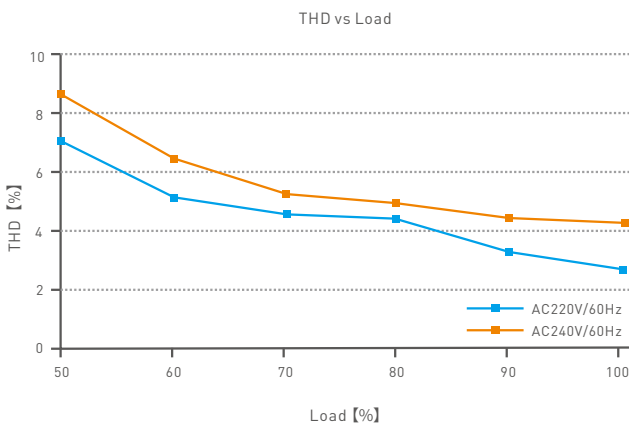
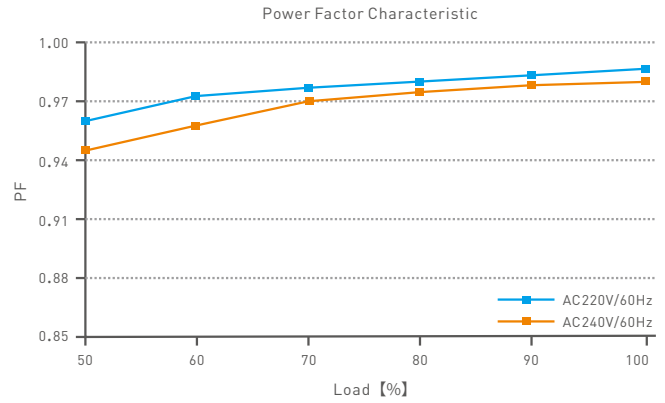
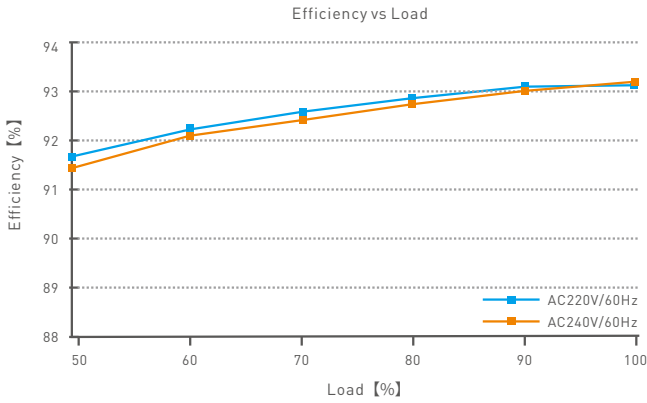

Flicker Test Table

Limit Value of Modulation in Low Risk Areas	
Waveform frequency of optical output (f)	Limit value (%)
$f \leq 8\text{Hz}$	0.2
$8\text{Hz} < f \leq 90\text{Hz}$	$0.025 \times f$
$90\text{Hz} < f \leq 1250\text{Hz}$	$0.08 \times f$
$f > 1250\text{Hz}$	Exemption assessment
Limit Value of Modulation in No Effect Areas	
Waveform frequency of optical output (f)	Limit value (%)
$f \leq 10\text{Hz}$	0.1
$10\text{Hz} < f \leq 90\text{Hz}$	$0.01 \times f$
$90\text{Hz} < f \leq 3125\text{Hz}$	$[0.08/2.5] \times f$
$f > 3125\text{Hz}$	Exemption assessment (High frequency exemption)

- Brightness
- ▲ 0.1%
 - ◆ 1%
 - ▲ 5%
 - ◆ 10%
 - 20%
 - ▲ 30%
 - 40%
 - ★ 50%
 - 60%
 - 70%
 - 80%
 - ★ 90%
 - ◆ 100%

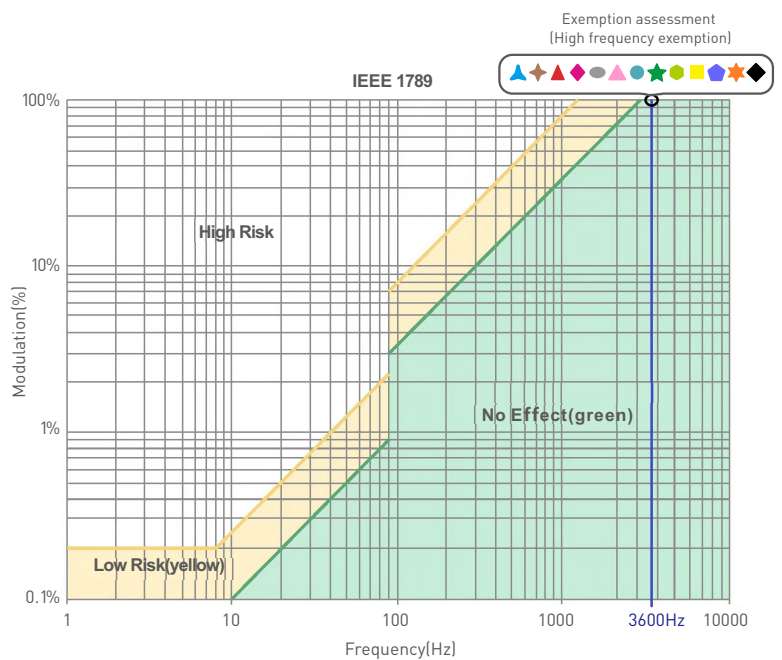

Marks in the right chart are tested results of different current levels. The output frequency is 0Hz in 100% brightness and its corresponding modulation is 0%, which could not be shown in the right chart.

System Diagram

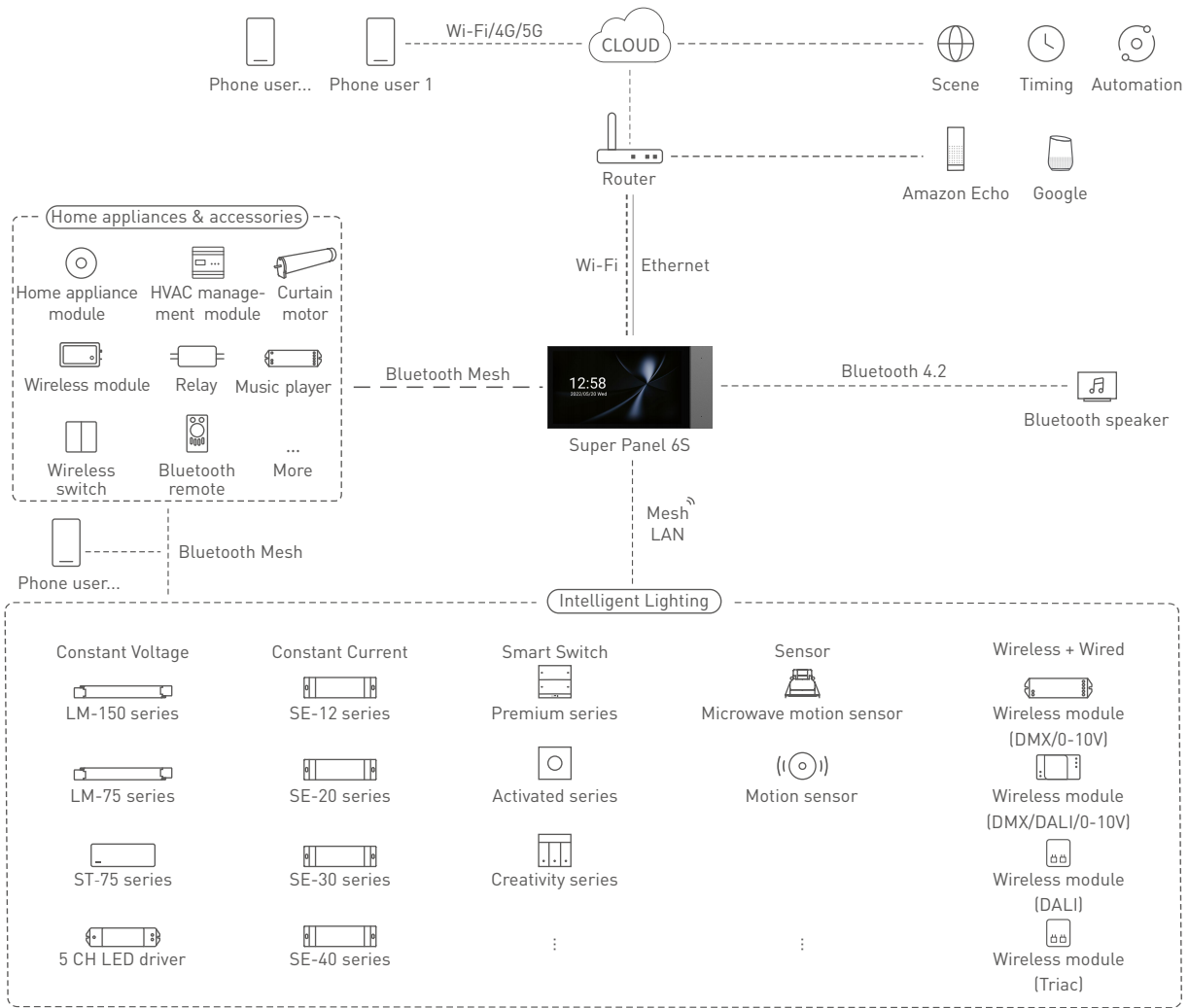

Recommend Applications

1. Achieve fast dimming control.

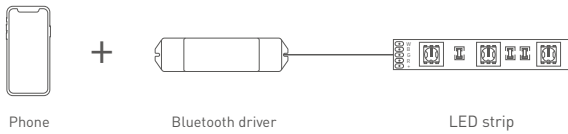

2. Both App and remote can control the driver after connecting the remote to the driver with App.

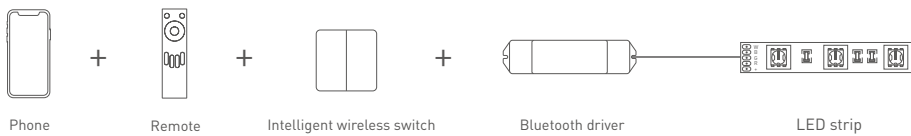

3. Both App and Super Panel 6S can control the driver simultaneously after connecting the Super Panel 6S to the driver with App. By connecting the Super Panel to network, you are allowed to control the driver, cloud scenes and automation remotely with App.

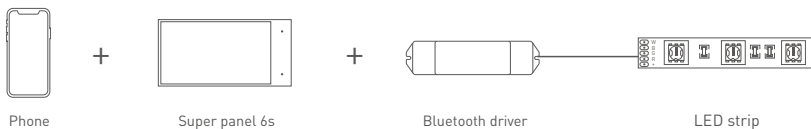

4.More applications of intelligent control are waiting for you to set up.

App Operating Instructions

1. Register an account

The App is available on iOS or Android devices. Scan the QR code below with you mobile phone and follow the prompts to complete the App installation. Open the App to log in or register an account.



Scan and download the APP

2. Paring instructions

Open the APP and create a home if you are a new user. Click "+" icon in the upper right corner and access the "Add Device" list, Pick "Smart lighting-RGBW light[BLE]" from the list and follow the prompts to power on the device firstly. Make sure the device is not connected to the network. Then click "Bluetooth Search" and follow the prompts to add the device.

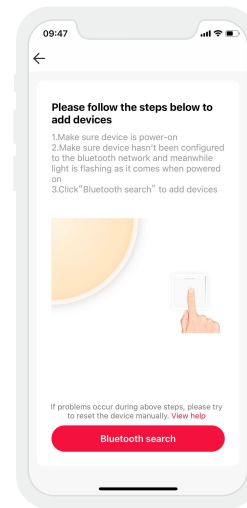
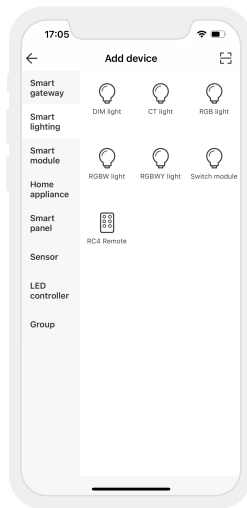
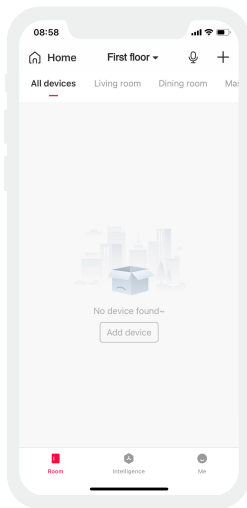

3. Control interface settings

After pairing up your device, go to the control interface. You'll be able to achieve your desired lighting effects by changing brightness and color temperature and colors. Click "Theme" and you'll easily switch to multiple theme lighting effects with one tap. Click "Mode" and the App provides you editable advanced modes. Customize dynamic modes to put you into a more colorful life.

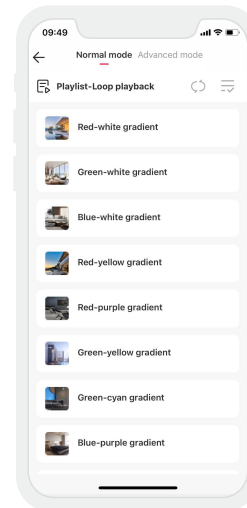
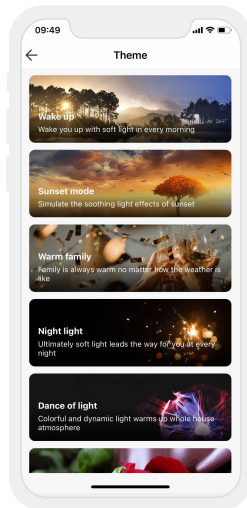
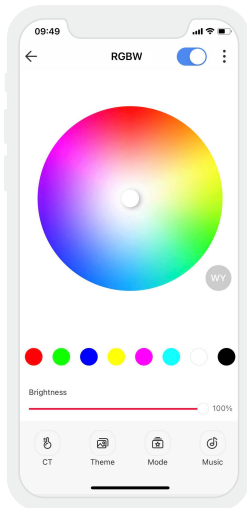

4. Light groups

Users are able to combine the same type of light fixtures into a group to control them simultaneously. Once you create the group, you can set the dim level and adjust the color of lights more easily. Pick "Group-RGBW light group" from the list . Follow the prompts to rename the group and click "Next" to pick the lights you are going to group together and click "Save".

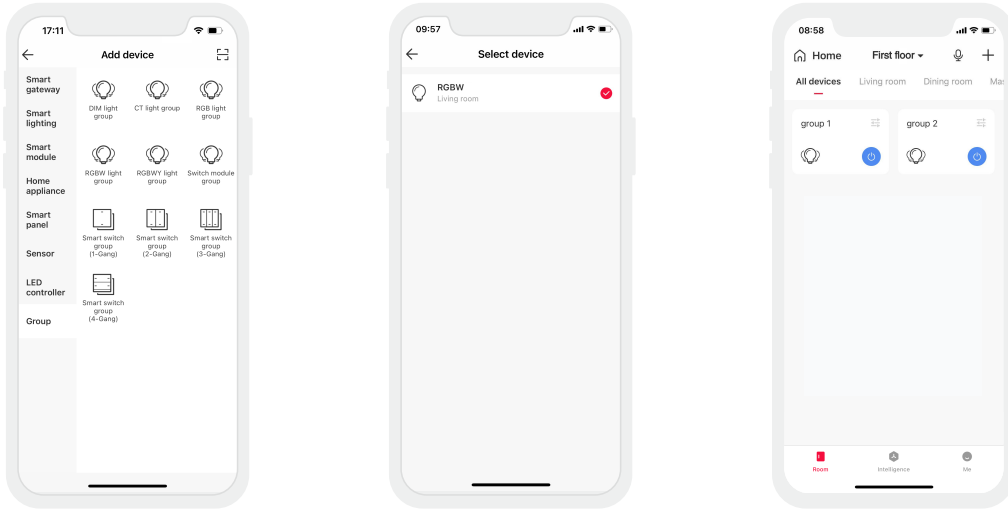

5. Advanced functions

This driver can be linked up with gateway function devices (such as Super Panel 6S) to achieve the advanced functions from local scenes and cloud scenes to automation.

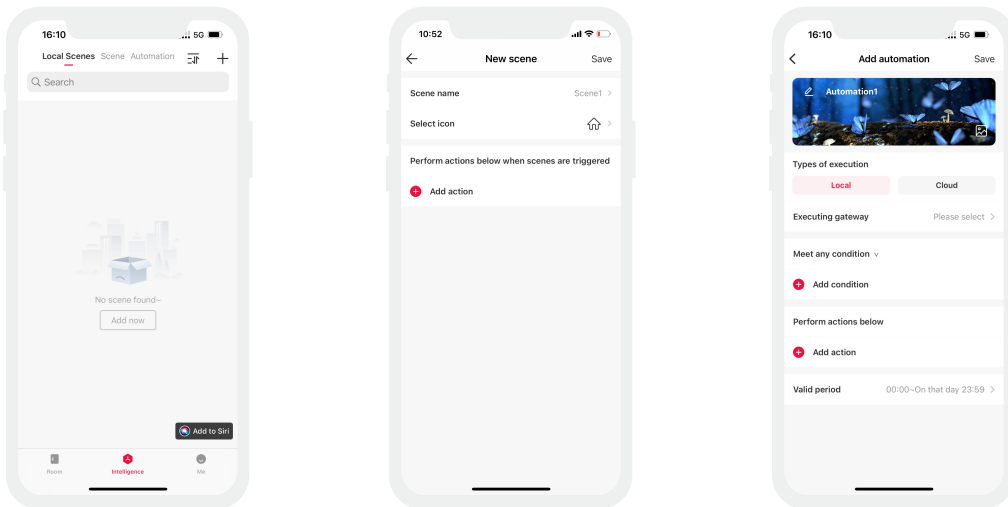

Reset The Device (Reset to factory defaults)

Make sure the driver is well-connected to a lamp and the lamp is on, turn it off with the switch and after 15s turn it on. After 2s, turn it off again. Repeat the same operation 6 times. When the lamp flashes 5 times , reset the device to factory defaults successfully.

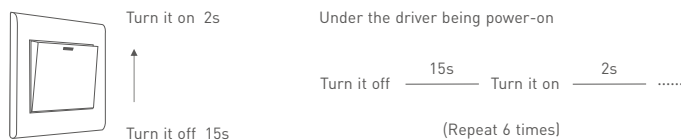

Packaging Specifications

Model	LM-150-24-G4B1
Carton Dimensions	370x340x93mm[LxWxH]
Quantity	10 PCS/Layer; 2 Layers/Carton; 20 PCS/Carton
Weight	0.43 kg/PC; 9.4 kg/Carton

Packaging Image



Inner Packaging Box



Carton Packaging

Transportation and Storage

1. Transportation

Products can be shipped via vehicles, boats and planes.

During transportation, products should be protected from rain and sun. Please avoid severe shock and vibration during the loading and unloading process.

2. Storage

The storage conditions should comply with the Class I Environmental Standards. The products that have been stored for more than six months are recommended to be re-inspected and can be used only after they have been qualified.

FAQs

1. What should I do if I fail to add the device?
 - 1.1 Please make sure the device is powered on normally and is in the activated mode.
 - 1.2 Please make sure the device hasn't been added by any other account. If it did, please reset to factory defaults manually.
 - 1.3 The recommended distance between the mobile phone and the device is no more than 20 meters.
 - 1.4 If the device has been forced to delete, please reset to factory defaults manually and then add the device again.
2. What should I do if the device disconnects from the network?
 - 2.1 Please make sure the device is powered on normally.
 - 2.2 Please make sure the router works normally and the network runs smoothly.
 - 2.3 If you control the device remotely, please make sure your phone network runs smoothly.
3. How to control remotely and set cloud scenes?

Remote control and cloud scenes can be achieved only by working with LTECH Super Panel.
4. How to share control of your home devices?

Please go to "Me" - "Home Management" and access the home you want to share. Click "Add Member" and follow the prompts to add members into your home.

Attentions

- This product must be installed and adjusted by a qualified professional.
 - This product is non-waterproof (special models excepted). Please avoid the sun and rain. When installed outdoors, please ensure it is mounted in a water proof enclosure.
 - Good heat dissipation will extend the life of the product. Please install the product in an environment with good ventilation.
 - When you install this product, please avoid being near a large area of metal objects or stacking them to prevent signal interference.
 - Please keep the product away from an intense magnetic field, a high pressure area or a place where lightning is easy to occur.
 - Please check whether the working voltage used complies with the parameter requirements of the product.
 - Before you power on the product, please make sure all the wiring is correct in case of incorrect connection that may cause a short circuit and damage the components, or trigger an accident.
 - If a fault occurs, please do not attempt to fix the product by yourself. If you have any question, please contact the supplier.
- * This manual is subject to changes without further notice. Product functions depend on the goods. Please feel free to contact our official distributors if you have any question.

Warranty Agreement

- Warranty periods from the date of delivery: 5 years.
- Free repair or replacement services for quality problems are provided within warranty periods.

Warranty exclusions below:

- Beyond warranty periods.
- Any artificial damage caused by high voltage, overload, or improper operations.
- Products with severe physical damage.
- Damage caused by natural disasters and force majeure.
- Warranty labels and barcodes have been damaged.
- No any contract signed by LTECH.

1. Repair or replacement provided is the only remedy for customers. LTECH is not liable for any incidental or consequential damage unless it is within the law.
2. LTECH has the right to amend or adjust the terms of this warranty, and release in written form shall prevail.

Update Log

Version	Updated Time	Update Content	Updated by
A0	2021.09.13	Original version	Liu Weili
A1	2022.02.28	Update output terminal wire diameter and stripping length	Liu Weili
A2	2023.03.15	The warranty period is changed to 5 years	Liu Weili
A3	2024.06.07	Updated silk screen to the latest version and removed corresponding certification icons	Li Siyu

LED智能全彩驱动器 (恒压型)

- 体积小、重量轻；外壳采用科思创/三星PC阻燃V0级原料
- 免螺丝压线翻盖设计，可拆卸端盖，按需调节壳体长度
- Bluetooth 5.0 SIG Mesh通信协议，组网能力强，可靠稳定
- 支持iOS和安卓智能设备蓝牙直连控制
- 带软启动渐亮功能，让人眼视觉更舒服
- 调光范围0~100%，LED从0.1%开始调光
- 符合欧盟能效EPR指令，待机功耗<0.5W
- Class 2电源，SELV安全特低电压
- 信号光电隔离设计，更加安全可靠
- 创新的热管理技术，智能保护电源寿命
- 短路、过温、过载、过压保护，可自动恢复
- 高达50,000小时的额定寿命
- 5年保修期 (采用红宝石电容)

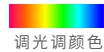

无频闪
IEEE 1789
高频豁免考核级别

Dimmable:
0.1%-100%



RoHS

SELV



认证图标仅代表产品正在进行一系列的认证申请，认证资质以产品实物为准。

技术参数

型号	LM-150-24-G4B1			
特征	输出类型	恒压		
	调光类型	Bluetooth 5.0 SIG Mesh		
	输出特征	隔离		
	防护等级	IP20		
	绝缘等级	II类 (适用于室内 I、II、III类灯具)		
输出	输出电压	24Vdc		
	输出电压范围	24Vdc ± 0.5Vdc		
	输出电流	Max. 6.25A (1.56Ax4CH)		
	输出功率	Max. 150W		
	输出功率范围	0~150W		
	频闪级别	高频豁免考核级别		
	调光范围	0~100%，调光深度: Max. 0.1%		
	过载功率限制	≥102%		
	纹波与噪声	开关纹波≤150mV，噪声≤300mV		
	PWM调光频率	3600Hz		
输入	直流电压范围	200-280Vdc		
	交流电压范围	198-264Vac		
	额定电压	220-240Vac		
	频率范围	50/60Hz		
	输入电流	≤0.75A/230Vac		
	功率因数	PF>0.98/230Vac (满载)		
	谐波THD	THD<6%@230Vac (满载)		
	效率(Typ.)	93%		
	待机功耗	<0.5W		
	浪涌电流	冷启动, 45A (在50%peak下测twidth=840us)@230Vac		
	抗浪涌	L-N: 2KV		
	漏电流	Max. 0.5mA		
环境	工作温度	ta: -20 ~ 50°C tc: 85°C		
	工作湿度	20 ~ 95%RH, 无冷凝		
	储存温度/湿度	-40 ~ 80°C/10~95%RH		
	温度系数	±0.03%/°C(0-50°C)		
	耐振动	10-500HZ, 2G 12分钟/周期, X,Y,Z轴各72分钟		
保护	过温保护	根据PCB温度超标情况(>110°C), 智能调节电流输出或关闭, 可自动恢复		
	过载保护	负载电流≥102%, 关闭输出, 可自动恢复		
	短路保护	输出线路短路进入打嗝模式, 可自动恢复		
	过压保护	空载电压≥28V, 关闭输出, 可自动恢复		
安规和电磁规格	耐压	输入对输出: 3750Vac		
	绝缘阻抗	输入对输出: 100MΩ/500VDC/25°C/70%RH		
	安全规范	CCC	中国	GB19510.1, GB19510.14
		CE	欧盟	EN61347-1, EN61347-2-13, EN62384
	电磁兼容发射	CCC	中国	GB/T17743, GB17625.1
		CE	欧盟	EN55015, EN61000-3-2, EN61000-3-3, EN61547
电磁兼容抗扰度	EN61000-4-2,3,4,5,6,8,11, EN61547			
频闪测试标准	IEEE 1789			
其他	产品重量	430g±10g		
	产品尺寸	352×43×30mm(L×W×H)		

本款驱动器适合连接电阻限流的LED灯具 (如LED灯条)。如果连接内置恒流IC限流的灯具, 会产生几十倍的瞬间浪涌电流, 导致驱动器会执行过载保护 (打嗝频闪)。下单时这类内置恒流IC限流的灯具需要注明 (如MR16灯杯、地理灯、洗墙灯、恒流硬灯条等), 以便烧写特殊程序。

尺寸图

单位: mm

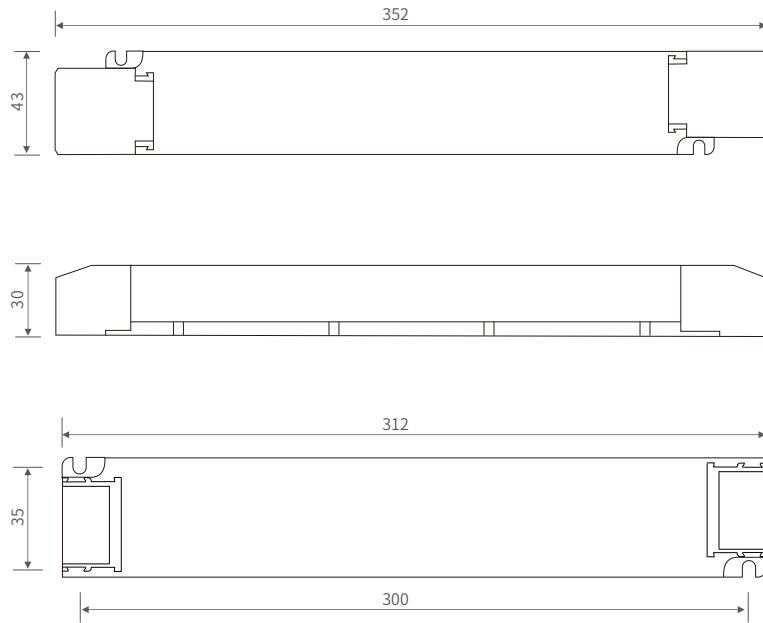

连接应用图

无线连接方式

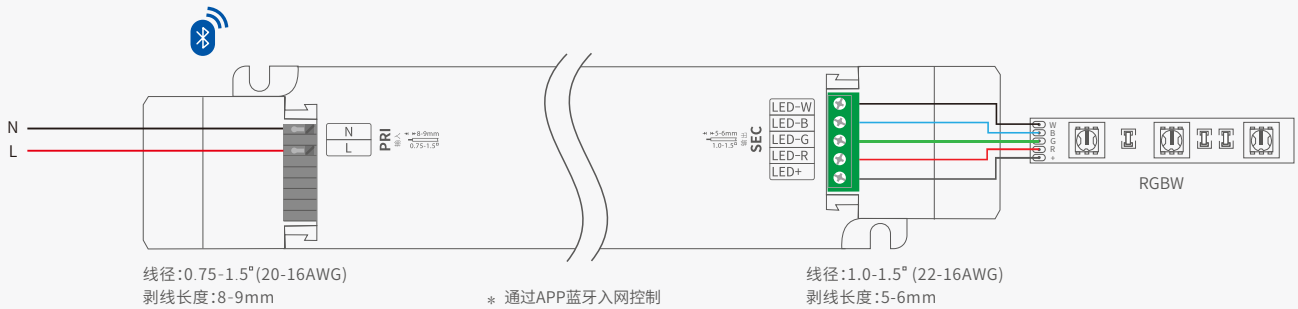

保护盖应用图

压线安装

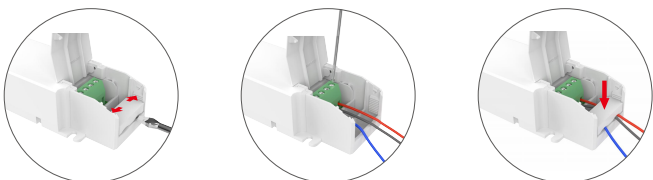

打开保护盖, 向外推压侧板并用螺丝批向上撬起将压线板拆下, 按照接线图接线后向下按压线板固定住线, 合上保护盖即可。

保护盖拆卸

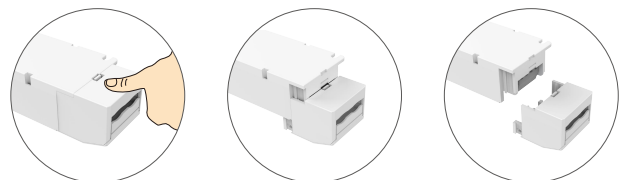

在外壳底部往下按压并左右拨动, 即可将保护盖拆下。

关系图表

效率与负载关系图

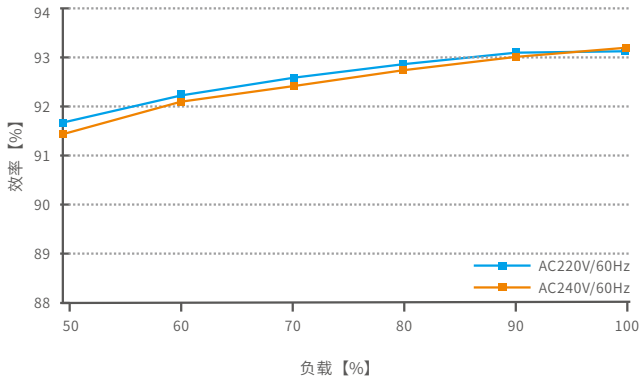

功率因素特征图

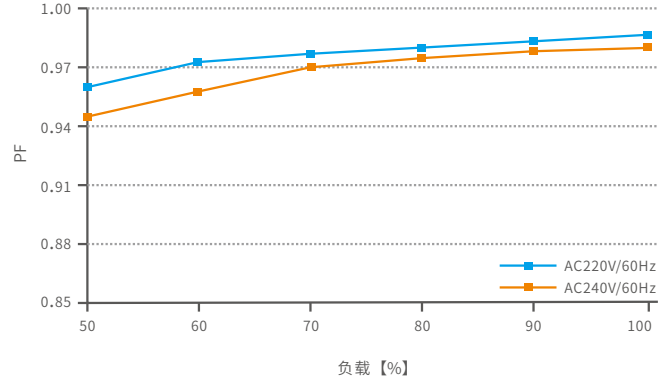

THD与负载关系图

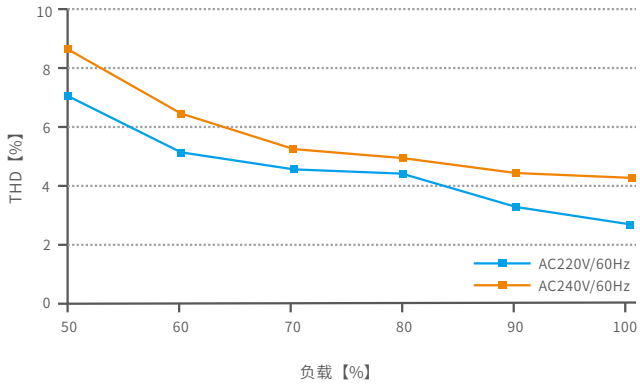

过载曲线

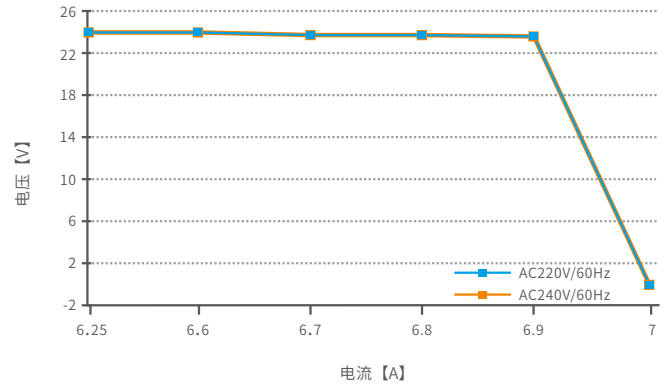

频闪测试表

IEEE 1789

低风险区域 (Low Risk) 的波动深度 (Modulation) 限值	
光输出波形频率 (f)	限值 (%)
$f \leq 8\text{Hz}$	0.2
$8\text{Hz} < f \leq 90\text{Hz}$	$0.025 \times f$
$90\text{Hz} < f \leq 1250\text{Hz}$	$0.08 \times f$
$f > 1250\text{Hz}$	免除考核
无风险区域 (No Effect) 的波动深度 (Modulation) 限值	
光输出波形频率 (f)	限值 (%)
$f \leq 10\text{Hz}$	0.1
$10\text{Hz} < f \leq 90\text{Hz}$	$0.01 \times f$
$90\text{Hz} < f \leq 3125\text{Hz}$	$(0.08/2.5) \times f$
$f > 3125\text{Hz}$	免除考核(高频豁免)

亮度

- ▲ 0.1%
- ◆ 1%
- ▲ 5%
- ◆ 10%
- 20%
- ▲ 30%
- 40%
- ★ 50%
- 60%
- 70%
- ◆ 80%
- ★ 90%
- ◆ 100%

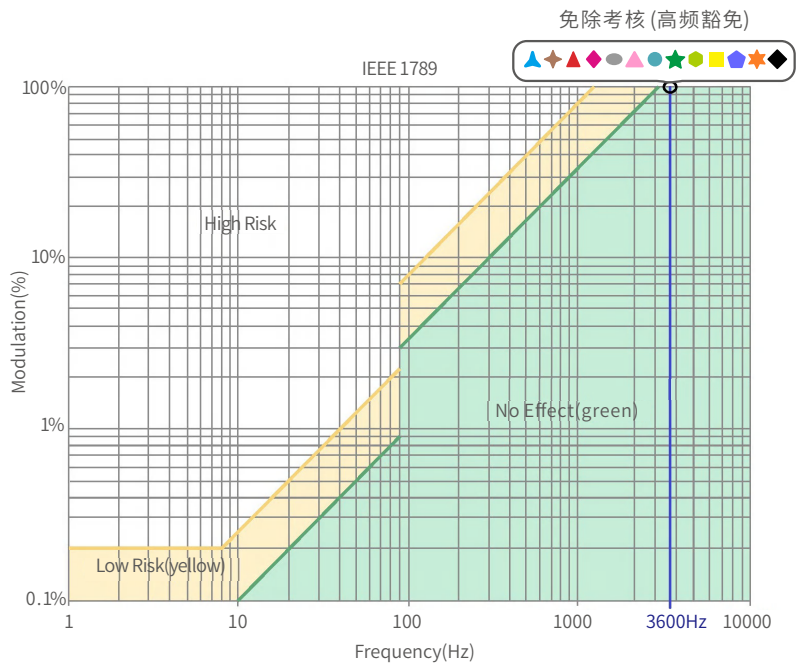

右图标识为不同电流档的测试结果。

100%亮度时输出频率为0Hz, 对应波动深度为0%, 无法在右图中示意。

系统图

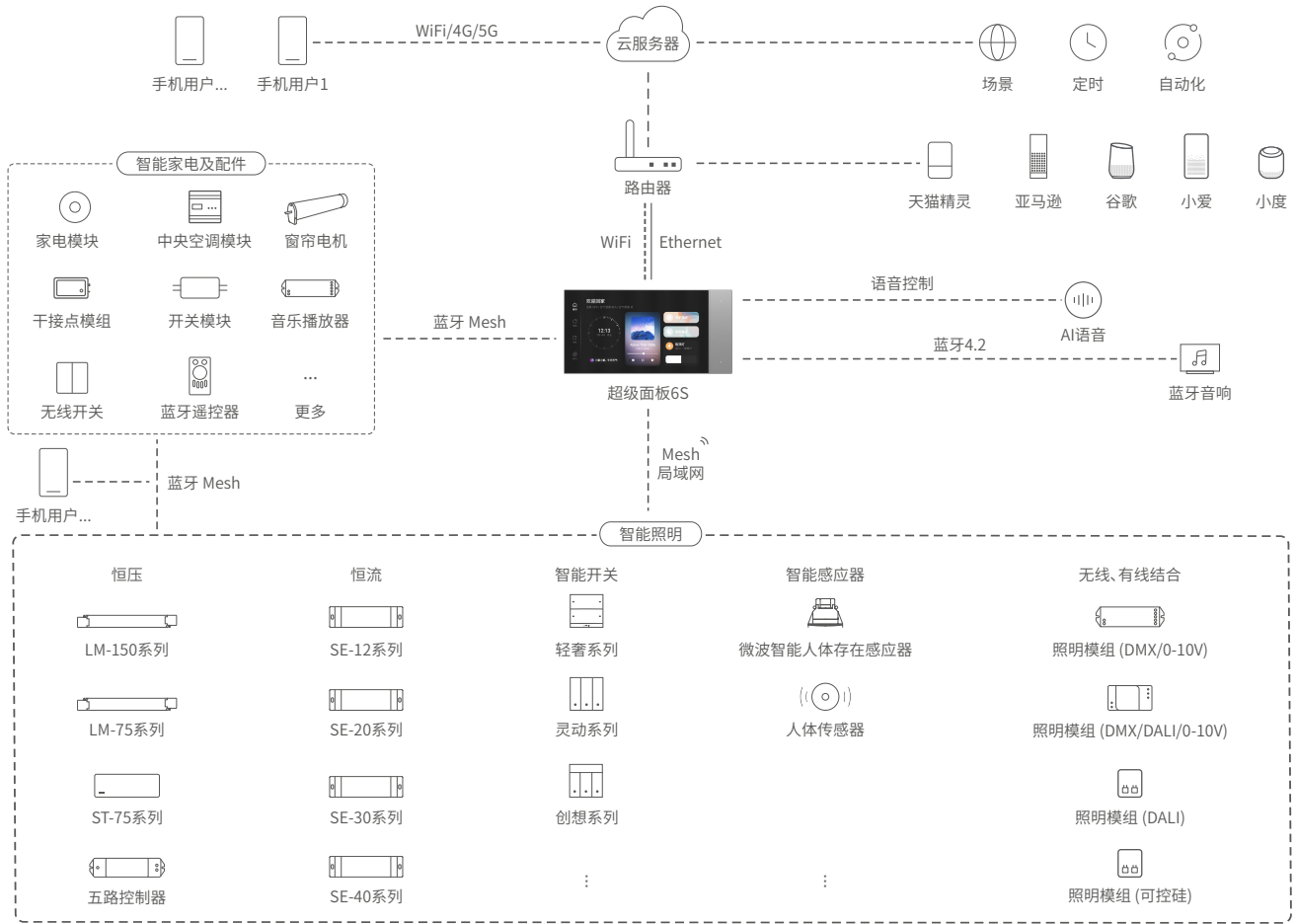

推荐应用控制方式

1、快速实现本地调光。

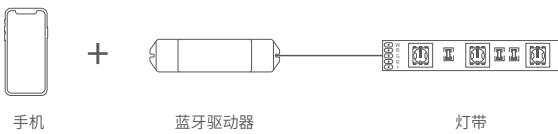

2、通过APP设置遥控关联驱动后，可实现APP与遥控两种控制方式控制驱动。



3、通过APP设置面板关联驱动，可实现APP与面板同时控制。并能够通过面板联网，可实现APP远程控制驱动，云场景，自动化联动功能。

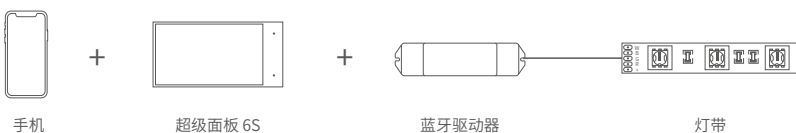

4、.....智能控制，更多应用搭配等您来设置。

APP操作说明

1. 账号注册

APP兼容iOS和Android系统，通过手机扫描下方二维码，按提示完成APP安装,安装后即可进行登录/注册操作。



扫码下载APP

2. 配对操作

新用户创建家庭后，点击右上角“+”进入添加设备列表，在添加设备列表中选择“智能照明-彩光RGBW灯”后，按照界面提示，先将设备接通电源，确保设备处于未入网状态。然后点击“蓝牙搜索”后，按照提示完成添加设备。



3. 控制界面设置

配对完成后，进入控制界面，可以通过调节颜色、色温，亮度达到想要的灯光效果。点击主题，进入主题界面，可一键切换多种主题灯光效果。点击模式，具有可编辑的高级模式。自定义动态模式，让您的生活更加丰富多彩。

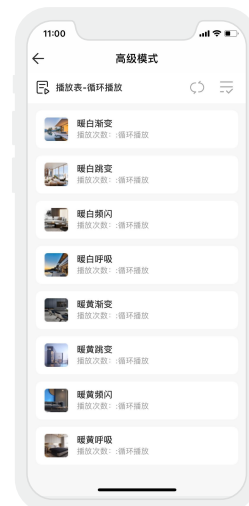
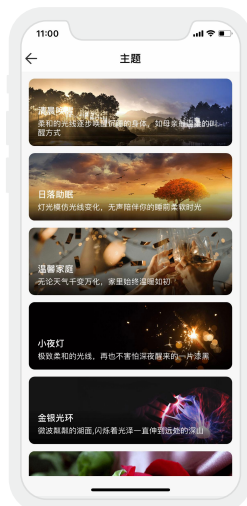
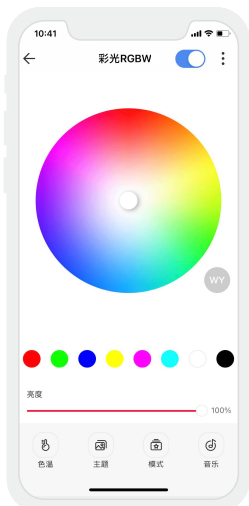

4. 灯具群组

同类型的灯具可以组成群组，用户可以对群组进行调色、调光等操作，操作更加便利。在添加列表中选择“群组—彩光RGBW灯组”，按照界面提示编辑灯组名称后，点击“下一步”，勾选您要组成群组的设备，保存即可。

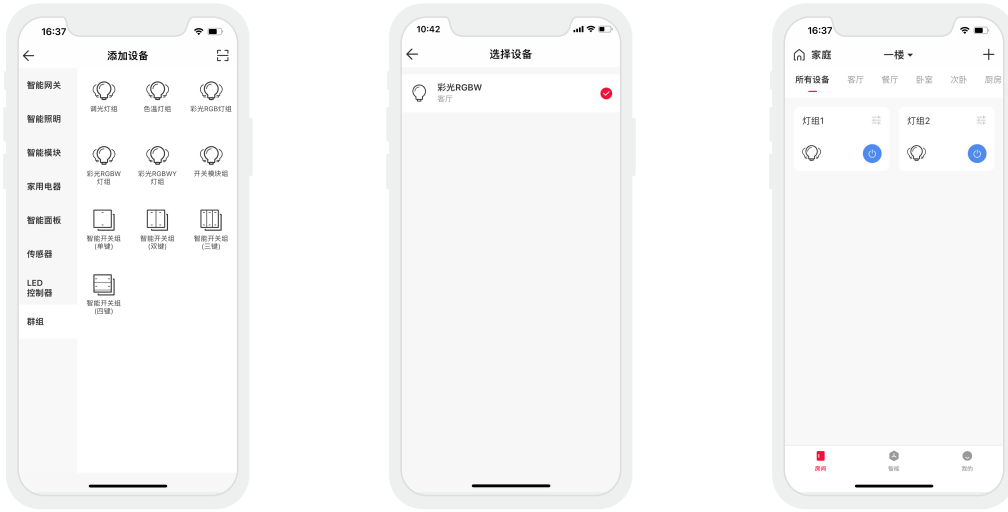

5. 高级功能

本产品可以通过与具有网关功能的设备联动，如超级面板GS。可实现本地场景、云场景、自动化等高级功能。



重置设备(恢复出厂设置)

确保驱动已接灯具且处于常亮状态下，使用开关让驱动连续断通电6次(每次断电时间15秒，通电2秒)，第六次通电2秒后，灯具闪烁5次，即表示驱动已恢复到出厂设置状态。

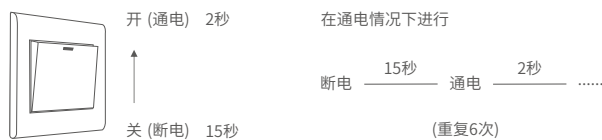

包装规格

型号	LM-150-24-G4B1
包装箱尺寸	370×340×93mm(L×W×H)
数量	10 PCS/层; 2层/箱; 20 PCS/箱
重量	0.43 kg/PC; 9.4 kg/箱

包装样式图



内包装盒



整箱包装

运输和贮存

1. 运输

产品适用车、船、飞机交通运输工具运输。

在运输中，应使用遮篷进行防雨和防晒，并保持文明装卸，不应有剧烈振动、撞击等。

2. 贮存

贮存符合 I 类环境的规定。贮存期限超过6个月的产品建议重新检验，合格后方可使用。

常见问题

1. 设备添加失败怎么办？

- 1.1 确保设备正常通电，并且处于激活状态；
- 1.2 需要添加的设备未被其他账号添加过，如被添加过，请手动恢复出厂；
- 1.3 确保手机与设备两者尽量靠近，建议不超过20米；
- 1.4 如设备已被强制删除，请手动恢复出厂，然后重新添加设备。

2. 设备离线怎么办？

- 2.1 请检查设备是否正常通电；
- 2.2 请检查路由器是否工作正常，网络畅通；
- 2.3 如使用远程控制，请检查手机网络是否工作正常，网络畅通。

3. 如何远程控制/云场景设置？

如需远程控制/添加云场景设置，需搭配本司超级面板方可使用。

4. 如何共享设备？

请在“我的” — “家庭管理”，进入需要共享的家庭，点击“添加成员”，请按提示将需要设备共享的家人/朋友加入该家庭即完成共享。

注意事项

- 请由具有专业资格的人员进行调试安装；
 - 雷特产品(专有型号除外)不能防水,需避免日晒雨淋,如安装在户外,请用防水箱;
 - 良好的散热条件会延长产品的使用寿命,请把产品安装在通风良好的环境;
 - 请检查使用的工作电压是否符合产品的参数要求;
 - 使用的电线直径大小必须能够负载连接的LED灯具,并确保接线牢固;
 - 通电调试前,应确保所有接线正确,以避免因接线错误而导致灯具损坏;
 - 如果发生故障,请勿私自维修;如有疑问,请联系供应商。
- * 本说明书的内容如有变更,恕不另行通知。若内容与您使用的功能有所不同,则以实物为准。如有疑问,欢迎向我司授权的经销商咨询。

保修条例

- 自出厂之日起保修服务期为5年。
- 在保修服务期内出现产品质量问题雷特将给予免费修理或更换服务。

非保修条例:

属下列情况不在免费保修或更换服务范围之内:

- 已经超出保修服务期;
 - 过高电压、超负载、操作不当等人为造成的损坏;
 - 产品外形严重损坏或变形;
 - 自然灾害以及人力不可抗拒原因造成的损坏;
 - 产品保修标签和产品唯一条形码损坏;
 - 无雷特签订的合同或发票凭证。
1. 修理或更换是雷特对客户唯一补救措施。雷特不承担任何附带引起的损害赔偿,除非在适用法律范围之内。
 2. 雷特享有修正或调整本保修条款的权利,并以书面形式发布为准。

更新日志

版本	更改日期	更改内容	更改人
A0	2021.08.05	正稿	刘伟丽
A1	2022.02.28	更新输出端子线径和剥线长度	刘伟丽
A2	2023.03.15	将保修期修改为5年	刘伟丽
A3	2024.06.07	丝印更新为最新的版本,去除相应认证图标	李思雨